

King Fahd University of Petroleum and Minerals
AEROSPACE ENGINEERING PROGRAM

*

AE 220 PROJECT
HOVERCRAFT

*

Team Members:

*SALMAN AL-FAIFI, KHALID AL-ANAZI, MOHAMED AL-FAIFI, MONIEF AL-MOTAIRI,
JIHAD AL-HAKAMI, MOHAMED AL-GAISI & HAKIM AL-MENHALI*

Directed by Dr: AHMAD AL-GARNI

Introduction

The hovercraft is one of the most versatile ground vehicles because of its ability to traverse nearly all kinds of terrain. The hovercraft was first developed for military use; Its primary use was for coastal insertions. This ability to operate on bare ground, water, ice, and snow makes the hovercraft a superior rescue vehicle.

Hovercrafts travel on a cushion of air trapped in a chamber beneath the craft. The chamber consists of the hull and synthetic skirting material. It must be continuously supplied with air under pressure via a lift fan, replacing the air escaping from beneath the bottom edge of the chamber. A high-pitch propeller supplies the thrust air which flows over pivoting rudders to steer the vehicle.

The team has separated the hovercraft design into four major areas: body, lift, propulsion, and controls. The body consists of expanded polystyrene foam inlaid with wood framing and sealed with a urethane coating. The lift system uses a vertical shaft engine and a multi-blade fan, to force air into the synthetic fabric skirt. The skirt acts to stabilize the vehicle, while trapping a cushion of air under the craft. The vehicle is propelled to a large adjustable-pitch thrust propeller, driven by a snowmobile engine. Engine speeds and pivoting rudders behind the propeller are used to control the operation of the hovercraft.

Proven hovercraft designs serve as the foundation for the team's project. Modern materials and components are being employed to build upon existing designs and to produce a hovercraft that is safe, reliable, and versatile.

Design

- (1) All rotating assemblies should be designed to prevent failure over the entire life of the components and machine. Design for stresses imposed at 50% above maximum RPMs

- (2) The maximum tip speed of a propeller should not exceed 675 FPS and lift fans should not exceed 500 FPS. Multi-wing fans should not exceed 400 FPS. Lower fan-prop speed lowers noise to a greater extent
- (3) Materials for fans and propellers should be carefully selected. Wood blades should be laminated (2 or more laminations – The more laminations the better) and continuous throughout the hub. Blade cross sectional area should increase from tip to root. Wood used for prop and fans should have a straight grain running length wise
- (4) Positive locking devices (cotter pins, safety wire, etc.) should be used on engine mounting bolts, air filters, exhaust systems, props and fans, or where ever loose parts could fall into the fan or propeller. Mount structures should be of the fail safe type (if any part breaks or comes loose the remaining parts will take the maximum load without failing. In the case of rubber vibration isolator mounts extra mounts may have to be used to meet this requirement. (Note: All critical parts must be inspected before every run.)
- (5) Engine exhaust gases should not enter shirt or cushion area.
- (6) Exhaust piping must not be closer than 2 inches from flammable parts (wood, fiberglass, etc.). Hot parts must be shielded from contact by people or equipment during normal and emergency craft operations.
- (7) Fuel systems should comply with US Coast Guard standards. Kill switches should be installed to quickly kill engines and stop the craft in an emergency. A dead-man ignition switch which shuts down the thrust engine if the pilot is thrown out must be used.
- (8) Craft must float off cushion with 150% of maximum payload. Craft must float with a punctured hull and full payload. Additional widely space floatation should be used in cold weather to keep all occupants completely dry.
- (9) Safety glass or transparent plastic (Plexiglas, Lexan, etc.) shall be used for glazing.
- (10) All crafts shall have clearly obvious and adequate handling points on front, sides and aft which may be used to pull it from water, to tow craft or for general handling.
- (11) Provisions must be made for restarting engines when on water.
- (12) Adequate all around vision shall be provided from the drivers seat either directly or by use of mirrors.
- (13) Noise level should be as low as possible, and should not exceed 80 DBA for cruising. (measured 50 ft. from craft) Damage to hearing can result from exposure to loud noise. Some primary sources of noise on Hovercraft which should be considered are:
 - A. High tip speed on fans and props.
 - B. High horsepower on small fans and props.
 - C. Obstructed airflow to fans-props.
 - D. Lack of vibration isolator mounts on machinery.
 - E. Poor or no exhaust silencers.
 - F. High revving engines especially air-cooled engines.
 - G. Lack of intake silencers.
 - H. Lack of sound absorptive materials at critical places.

- (14) A fire extinguisher of at least 2 lb. Capacity should be carried.
- (15) Electrical components in the ignition system (coil, distributor, etc.) should be protected from water spray (wrap in plastic or rubber) especially for saltwater operation.

Structure:

1. The hull of the craft must have strength enough to withstand plowing into the water at maximum speed and at any angle.
2. It must be capable of being towed at reasonable speed on water.
3. The hull must also be capable of floating on rough water without taking on water from waves splashing over sides, front or back.
4. Positive flotation in the form of Styrofoam, urethane foam or floatation air bags should be used on all crafts especially when traveling over cold water. In this case positive flotation should be capable of supporting gross weight (craft & passenger) plus 50%.
5. The lower edge of the hull should be angled to provide a planning surface in event of skirt collapse at speed over land or water.
6. Craft components shall be positioned so that if they break loose they are unlikely to cause injury to the occupants or else they must be capable of withstanding a 6 G deceleration.
7. The interior should be free of sharp edges.
8. The cabin should be strong enough to protect passengers if craft should overturn.

Guarding:

1. All rotating assemblies shall be guarded in such a way that, under all operating conditions, no part of a person or his clothing is likely to accidentally enter the space occupied by the rotating assembly, or force the guard or structure into that space, whether the person be in collision with, handling, or operating the craft.
2. Prop and fan perimeter (tip) guard should enclose the entire sweep volume on 54 inches and less diameters at least 5 inches in front and behind the rotor and have no openings larger than $\frac{1}{4} \times \frac{1}{4}$ inches if within 1 inch of blade tips; $\frac{1}{2} \times \frac{1}{2}$ inches if within 1-6 inches of tips and $2 \times 2 \frac{1}{2}$ if beyond 6 inches. For large (over 54" dia.) cruising props, guards must go to 72 inches high when on cushion.

3. Inlets to lift fans and thrust systems must have no opening larger than $\frac{1}{4} \times \frac{1}{4}$ inches if within 1 inch of rotor or $\frac{1}{2} \times \frac{1}{2}$ if within 1/6 inches of rotor 2 2 x 2 ½ if within 30 inches of rotor of 12 x 12 if beyond 30 inches.
4. Outlet guards must have no openings wider than $\frac{1}{4}$ inch if within 1 inch of rotor back; $\frac{1}{2}$ inch if 1/6 inches. Two inches wide for 6 to 12 inches of rotor back and 14 inches if beyond 12 inches from rotor. Outlet guards not required on lift systems. Note: An appropriate rudder or rudder and trim wing arrangement can meet this requirement for the outlet guard. On 48 inches through 54 inches diameter props and fans a trim wing within 14 inches for 54 inch props can meet these requirements.
5. The guard or structure must not deflect into the swept volume of the rotating device when a force of 100 lbs. is applied over an area 3.5 sq. inches at any critical area of the guard. This is to guard against the case of a person falling onto the guard and taking the impact load on one hand.
6. Consideration must be given in the design of the guard to provide for containment of the pieces, should the blade fail. Heavy blades running at high RPMs will require considerably stronger guard material than would be indicated by the test. Lift fans should be guarded to prevent broken blades from entering cabin area. Usually 1/32 in. steel or 1/16 in. aluminum or ¼ in. plywood extending half way around duct 3 inches above and 3 inches below the plane of rotation of the fan is adequate for most slow turning fans (3600 RPMs or less).
7. The most important aspect of safety around fans and propellers and Hovercraft in general is the attitude of persons, driver, crew, and others in areas where machines are running. All persons should be advised that if nuts, bolts, and other parts should come loose they can be thrown out at the speed of a bullet, generally in the plane of rotation of props and fans. Persons should be advised of the unusual characteristics of the craft especially in turning and stopping. The craft operator should not use full power when near spectators or near spectators are in the plane of rotation of propellers and closer than 200 ft. Operators should stop and shut down craft well in advance of spectators.

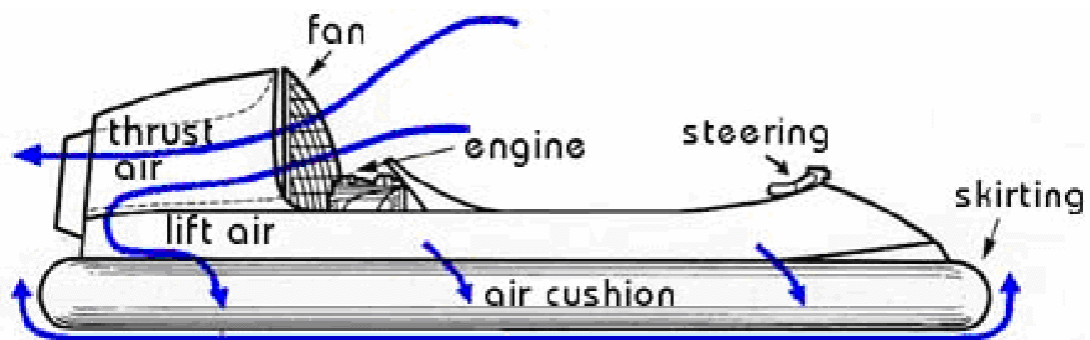

FIGURE 1 Components to Examine (Courtesy of Neoteric Hovercraft Inc.)

Design:

Thrust System:

The hovercraft thrust system is located on the rear of the vehicle. Power for thrust is produced by a Polaris 600cc two-cylinder motor. The motor will transfer power to a 64 inch diameter three-bladed variable pitch propeller. The power will be transferred via a two inch wide cog belt and cog pulleys sized to introduce an 8 to 3 reduction to ensure subsonic prop tip speed. A one inch steel shaft will be used between the driven pulley and propeller and the shaft will pass through several thrust pillow block bearings. The thrust motor and propeller assembly will be contained in a steel mounting frame. The mounting frame will be welded together from one-inch tubular steel. The frame will be constructed to hold the motor solid and also to secure the pillow block bearing and steel drive shaft which will run above the engine. The engine mounting frame will be placed on a 3/8" piece of plywood on a 6" raised foam deck at the rear of the hovercraft. Rubber mounts will be placed between the metal frame and plywood to dampen vibration. To produce a pushing thrust from the pulling type propeller, the engine will be mounted with the crankshaft towards the front of the hovercraft. This mounting arrangement will produce the necessary rotation of the propeller at the rear of the vehicle to produce thrust to move the craft forward. The entire engine will be enclosed in a protective wire mesh and a safety cage constructed of 1/2" bent metal conduit and wire screen will surround the thrust prop to prevent injury to operators, spectators, and propeller blades.

Lift System:

Lift for the system will be provided by a Briggs & Stratton 22hp engine mounted towards the front of the hovercraft. A four bladed lift fan mounted directly to the crankshaft of the engine will force air down through a 36" duct cut through the body of the craft. Metal guarding as well as warning placards will be provided at the top of the lift duct to prevent injury to operators or spectators. The engine and duct slope towards the rear of the craft at an 11 degree angle to increase efficiency of the lift fan. An air splitter will be located at the bottom of the lift duct to direct a portion of the air into the hovercraft skirt. The remainder of the air will be forced under the craft and provide the "hover" of the vehicle which will be 8" to 12" above the ground. The skirt will be constructed from a vinyl covered nylon material and be sewn to form a bag around the rectangular perimeter of the hovercraft. This bag skirt will trap air under the hovercraft, providing the elevated air pressure necessary to lift the vehicle off the ground.

Controls and Instrumentation:

A light metal control shaft will be run the length of the cabin to transfer control from a steering yoke to a cable and pulley system at the rear of the craft. This cable and pulley system will control three vertical steering rudders mounted behind the thrust propeller and one horizontal trim wing mounted above the vertical rudders. Other control cables may be routed through holes melted through the foam body of the hovercraft. Controls at the driver position will start and stop lift and thrust motors, control rpm of both motors, and control all rudders to change direction of travel of the

hovercraft. Dashboard instrumentation will monitor performance of engines, such as rpm and temperature, and will also provide information on the overall hovercraft to ensure everything is working properly.

Fluid Mechanics

Two main principles of fluid mechanics govern hovercraft lift. The first is the Bernoulli Principle: when airflow decelerates, there is an increase in static pressure. This is described with Bernoulli's equation (1).

$$P_1 + \frac{1}{2}\rho v_1^2 + \rho g z_1 = P_2 + \frac{1}{2}\rho v_2^2 + \rho g z_2$$

(P \equiv pressure, ρ \equiv density of fluid, v \equiv velocity of the fluid, g \equiv gravity, z \equiv height)

Due to the relatively low density of air, Bernoulli's equation reduces to the form

$$P_1 + \frac{1}{2}\rho v_1^2 = P_2 + \frac{1}{2}\rho v_2^2$$

The second principle that applies to the hovercraft is the conservation of linear momentum; an impulse on an object will produce a change in linear momentum.

$$\frac{\Sigma \mathbf{F}}{\Delta t} = \mathbf{P}_2 - \mathbf{P}_1$$

(\mathbf{F} \equiv force vector, \mathbf{P} \equiv momentum vector, and t \equiv time)

Now applying this principle to the airflow of the hovercraft, the equation reduces to the form

$$\Sigma \mathbf{F}_T = m_2 \mathbf{v}_2 - m_1 \mathbf{v}_1$$

(\mathbf{F}_T \equiv thrust vector, \mathbf{m} \equiv mass flow rate, and \mathbf{v} \equiv velocity vector)

Turbomachinery has two main operating conditions; both are used in modern hovercrafts. Closed-flow turbomachinery is where the system is operating in an enclosed area and the flow rates can be readily measured. The second is open-flow systems where there is no shroud that ducts the fluid and it is very difficult to measure flow rates. The first is the preferred because of the known flow, but both are readily used.

These two very basic principles provide the lift and thrust for the hovercraft, but losses due to friction, constricting flow and turbulent flow challenge the positive effects of fluid mechanics.

Lift:

The lift components of the hovercraft produce the basis of its operation, because they allow the vehicle to traverse land, water and snow with minimal contact with the surface. Lift is achieved by producing a pocket of air that has a pressure greater than that of the atmosphere around the craft. This pressure differential times the surface area that acts upon generates the lifting force for the hovercraft. The last statement makes it appear that this is an easy task to achieve, but the requirements and losses of the system change as the payload and terrain change. The components actively involved with the lift are the lift engine, lift fan, the hull and the skirting.

The lift fan is located in the front of the craft to produce the lift by two means, pressure differential and impulse/thrust. Calling this piece of closed-flow turbomachinery a fan may be deceiving, but by the properties of the airflow produced it is considered a fan and not a compressor. To achieve a significant hover height, the fan must deliver a significant amount of air (15,000 ft./min) at a very low pressure differential (.1234 psi). Eighty five percent of the lift is achieved by using the Bernoulli Principle and the impulse/thrust produces the remaining 15 percent.

With Bernoulli's principle, a pressure differential can be achieved by changing the velocity between two states. As the air is moved into the large cavity produced by the skirting and hull, it decelerates to a very slow velocity, thus increasing the pressure. As the pressure inside the skirt matches that required to lift the craft, a gap is created between the skirt and surface. Mass must be conserved therefore, air will begin to escape along this gap (Figure 2).

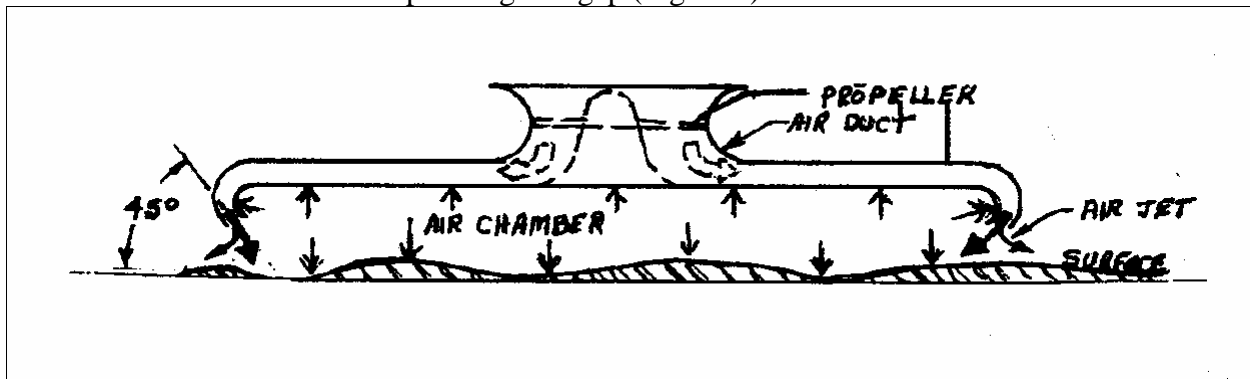

FIGURE 2 Airflow along skirt (Courtesy of Universal Hovercraft)

The rate at which this air is flowing is determined by Bernoulli's equation, because equilibrium must be obtained where the pressure remains equal to the weight of the hovercraft divided by its surface area.

The remaining portion of the lift is achieved by the conservation of momentum. As the air enters the duct it is moving at a relatively low velocity, the fan blades then act upon the air to increase its kinetic energy and linear momentum. The kinetic energy is a pressure source in Bernoulli principle. Since momentum is a vector quantity, each time it changes direction an impulse must be impulse applied. With a continual flow of air, it is simpler to define this as a force lifting up on the hull. As the flow continues to the aft of the hovercraft, the frictional and turbulent losses reduce the force applied.

Critical to the airflow, the power source for the fan must be able to meet the changing requirements of the craft. The weight of the hovercraft will vary from 1200 lbs. dry to 2400 lbs. with a full payload. This varying weight and surface conditions demand more from the fan and the motor driving the fan. The fan is able to transfer about 70 percent of the break horsepower to the air; therefore the motor must supply about 1.5 times that required. As the pressure necessary to lift the craft increases, the fan is able to supply the same or more air by applying the fan/pump laws (equation 5, Figure 3). As pressure head increases, the rotational velocity must increase at a squared rate.

$$\frac{P_2}{P_1} = \frac{N_2^2}{N_1^2}$$

(P ≡ pressure and N ≡ rotational speed)

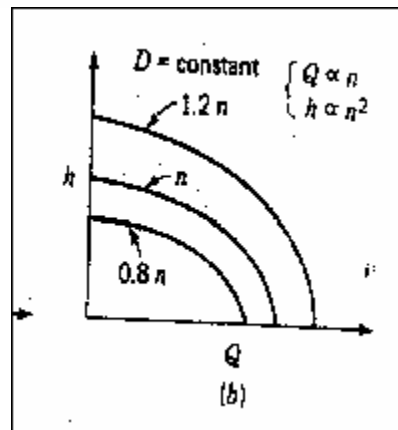

FIGURE 3 Head vs. Engine Speed (Courtesy of Fluid Mechanics, Frank M. White) The fan/pump laws requires that the motor must be able to operate a wide range of velocities, but there is a limiting factor. At standard atmospheric pressure and temperature, the velocity of sound is 1125 ft/s. As the velocity of the air reaches this speed, the airflow becomes extremely turbulent and the mechanical losses are very high. For this reason, the fan must be larger than 32 inches in diameter.

The hull also plays an important part in the lift section of the hovercraft. A duct that is created within the hull surrounds the fan. Tight tolerances must be kept with the clearance (less than 1/8") around the blades of the fan in order to maintain high efficiency. Another main concern is the entry and exit loss of the airflow. To reduce the entry loss, a radius is formed into the hull allowing a smooth transition from low velocity atmospheric air to the high velocity in the duct. A similar process is used for the exit, where a fillet is used to allow the transition from high to low velocity (Figure 4). The overall hull size also defines the payload that can be achieved; the greater the surface area, the lower pressure differential required.



FIGURE 4 Entry and Exit losses (Courtesy of Universal Hovercraft)

The final concern of the lift section is the skirt that entraps pressurized air. The skirting extends down from the hull to within a couple of inches of the ground and the exiting air travels horizontally along the parameter. A second enclosure, operating at slightly greater pressure, (Figure 5) is used to ensure stability and a constant surface for the main lift. As the skirt comes into contact with an obstruction, the secondary pocket is able to maintain a secure wall for the primary pocket. The material that the skirt is made of must be very durable because of possible surface contact and because if the pockets are punctured, lift is difficult to achieve.

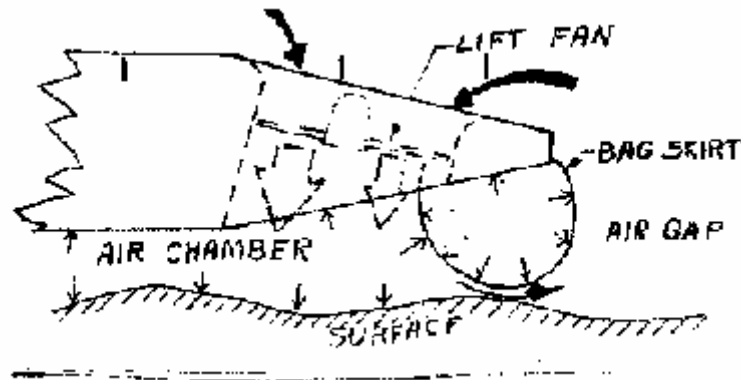

FIGURE 5 Secondary Enclosure (Courtesy of Universal Hovercraft)

As shown in the previous section, there are a great number of components that are directly related to the performance of the lift section. It is difficult to model these areas and be addressed in any hovercraft design.

Thrust:

The ability of the hovercraft to float on a cushion of air makes it a versatile vehicle, but also makes it a challenge to move it from point A to point B. The surface contact has been minimized, to reduce drag, to such a point that using the ground to propel the craft is no longer sound. The majority of today's hovercrafts use a vertical propeller, but a few models use thrust vectoring of the lift engines. Both the propeller dimensions and engine operating conditions play a vital part in thrust

The main principle of fluid mechanics that applies to propellers is the conservation of linear momentum. The majority of the turbomachinery props being used today are open-flow systems (Figure 6). The critical aspect of these propellers is that they must be provided adequate thrust to accelerate the craft and maintain operating speeds. This can be achieved by two means: adjusting the pitch of the blades or the diameter of the propeller. By adjusting the pitch of the blades, the blades can be made to catch more/less air with each pass, thereby changing the overall velocity of the air. The second method is to move more air by increasing/decreasing the area that the propeller is working with. These two are very critical considerations in order to match desired operating conditions and engine specifications.



FIGURE 6 Propeller (Courtesy of Neoteric Hovercraft Inc.)

The main challenge of the propeller assembly is to match the engine specification to the power requirements of the craft. With every engine, there are performance curves for power output, torque, and efficiency. There are a few desired operating states: low speed / maneuverability, high speeds, and efficiency. To achieve low speed / maneuverability, the engine torque curve is matched with a high pitch propeller. High speeds are achieved by using the power with a relatively high pitch propeller and, to achieve efficient travel, a low pitch propeller operating at the maximum efficiency point.

The final topic concerning the propeller, is the tip velocity. To operate at the most efficient point (normal operating), the standard four-cylinder motor will have an operating speed of about 3200-RPM. So to match this operating point with a propeller, the propeller must be 13 inches or must be geared down by a 4:1 ratio on a 54-inch blade to maintain the tip velocity below the speed of sound. The first would not be suitable for a craft other than a model, but the second would be able to achieve appropriate thrust for 2400 lb. vehicle, with blades having a pitch of 6 degrees. A two-cycle snowmobile engine has been donated to the SDSU team; this engine operates over a greater range of speeds; its normal operating speed is nearly 6000 RPM. Therefore the gearing must be at least an 8:1 ratio, but this may be increased for slower and more maneuverable operation. The propeller operating speed will also be a function of the pitch of the blades; testing will be done to match these two functions by using a variable pitch propeller and various gearing conditions.

The ability to hover above the ground is very important, but being able maneuver across the surface is what makes the hovercraft such a functional vehicle. For this reason a significant amount of consideration is give to propulsion after lift has been achieved.

Controls:

Another challenging area of a hovercraft that needs to be addressed is how it handles. Since the hovercraft is unlike the standard vehicle where there is continuous contact with ground, it handles quite differently than any other vehicle. The main concerns of any vehicle's handling are turning, stopping and maintaining lift.

The turning of the hovercraft is achieved by using a set of rudders along the exit flow of the thrust propeller. Rudders use the conservation of linear momentum to produce a reaction force by changing the direction of the airflow.

This reaction force is in opposite direction of that desired because it acts at the rear of the craft. The hovercraft behaves similar to jet skis, although they do not use a rudder. The Jet Ski makes a turn by directing the entire exit flow in the opposite direction

desired. The flow rate of the exit water is inversely proportional to the radius of the turn. Although not all of the airflow is used for turning the hovercraft, the same principle applies and thrust must be maintained to make a turn. To make a sharper turn, speed must be reduced first and then thrust must be applied to power through the turn.

The ability to stop is necessary for any vehicle and the hovercraft has two options. The first is achieved by turning the craft around and applying the thrust until it decelerates to a stop. The second option is to shut down the lift fan, allowing the skirt to deflate and drag on the surface. This process is normally left for emergencies or if the surface is soft or smooth, such as water, snow or ice.

The final operation to be controlled is the height of the craft. A few hovercrafts use a single engine to drive both the lift fan and the thrust, but their operation is limited. The independent lift engine allows the craft to maintain a hover height when the thrust engine is at idle. This is preferred when the surface is very rough or when the surface is moving such as on a river or with coastal waves. A second function, affecting the height of the craft, is the trim located at the rear of the craft with the rudders. The purpose of the trim is to level the hull so that the skirting is not dragging along the ground, damaging the skirt and increasing drag. The trim rudder (Figure 7) uses Bernoulli's principle to create a lift to raise the rear of the craft. The trim rudder is shaped like a wing so that the velocity of the airflow across the top is greater than below the rudder. With an increase in velocity, comes a reduction in pressure inducing lift because of the pressure differential between the top and bottom the trim rudder.

The characteristics of hovercraft are drastically different from most vehicles and use a variety of different ways to control the craft. Turning, stopping and maintaining lift are the challenges that designers must overcome when designing and building a hovercraft.

Specifications

Thrust System

The thrust motor used on the hovercraft is a Polaris 600 XC engine having an exact cylinder displacement of 593cc. This engine is rated to produce about 65hp at 4800rpm. The two-cylinder engine is liquid cooled with a self-contained water pump and will utilize an aluminum radiator from a Polaris ATV. The engine is equipped with a single pipe exhaust system and resonator box to muffle exhaust noises. The motor utilizes two 39mm Keihin carburetors that breath through K&N wire mesh air filters manufactured specifically for aftermarket options on these carburetors. The engine will drive a 64 inch diameter three-bladed thrust propeller. The pitch on the blades is adjustable to tune for maximum performance. Because the engine redlines at

8000rpm, a cog belt/pulley 8 to 3 reduction drive system will be used to keep the tip speed of the propeller below 675 feet per second.

References

1. Frank M. White, Fluid Mechanics, McGraw-Hill, Hightstown NJ (1994).
2. S. L Dixon, Fluid Mechanics and Thermodynamics of Turbomachinery, Butterworth-Heinmann, Woburn MA, (1998)
3. Universal Hovercraft, Hovercraft - Constructions and Operation, Universal Hovercraft, Cordova IL, (1994)
4. Neoteric Hovercraft, <http://www.neoterichovercraft.com/>
5. Universal Hovercraft, <http://www.hovercraft.com/>